



# TEQUATIC™ PLUS Filters

## Product Data Sheet



### Designed for Nasty, High-Solids Water

When compared with traditional suspended solids removal technologies, TEQUATIC™ PLUS Filters offer an innovative, self-cleaning solution for removing extremely high and variable solids from fluid streams, even in the presence of fats, oils and grease. TEQUATIC PLUS Filters, with their patented design, combine the power of continuously cleaning, cross-flow filtration with forced settling and solids collection into a single device.

### TEQUATIC™ PLUS Filter Operation

As shown in the illustration to the right, operation of TEQUATIC™ PLUS Filters is simple yet effective.

1. Pressure-controlled feedwater enters the unit and the water velocity across the filter screen initiates cross-flow filtration.
2. The feedwater flow drives the cleaning brush assembly, activating the cleaning mechanisms within the filter which continuously clean the filter screen, eliminating cake buildup.
3. Solids enter the recirculation and solids collection chamber. Heavy solids remain in the collection chamber while other particles flow into the recirculation pipe which feeds back into the feed inlet feedwater flow.
4. Concentrated solids are purged periodically for disposal or further processing.

### Application Examples

TEQUATIC™ PLUS Filters are an outstanding choice for removing solids in a variety of industrial wastewater treatment and reuse markets. Application examples include:

- TSS and particulate BOD, COD and TOC<sup>1</sup> reduction
- Pretreatment or cost-saving alternative to clarification, DAF<sup>1</sup> and aeration
- Pretreatment to downstream membranes and filters
- TSS reduction to protect disposal wells and facilitate reuse of frack flowback water

### Product Benefits

- Operate consistently where other filters typically fail
- Handle high TSS from 100–10,000 mg/L and greater, and filter down to 15 microns
- Capable of operating in the presence of fats, oils and grease
- Require no backwashes, and no to low chemicals
- Help customers realize:
  - Fewer compliance issues and/or lower surcharges and fines
  - Savings on maintenance, consumables and chemicals
  - High water recovery up to or >99%
  - High uptime and reliability in a small footprint (e.g. less waste, space and chemicals)
- Provide excellent flexibility:
  - Integrate into modular systems to meet capacity
  - Adjustable throughput and water recovery
  - Available in pre-engineered, skid-mounted systems for fast installation and startup (see skid datasheets)

Figure 1: Filter Process

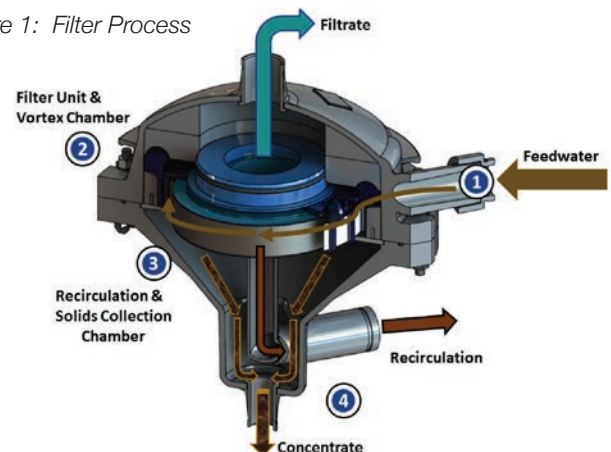

<sup>1</sup> TSS = total suspended solids; BOD = biological oxygen demand; COD = chemical oxygen demand; TOC = total organic carbon; DAF = dissolved air flotation

Figure 2: Dimensions and Fittings

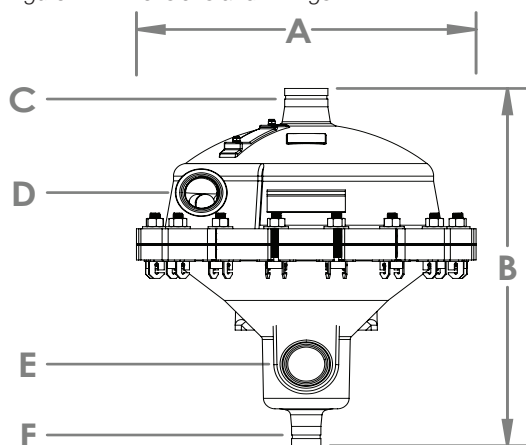
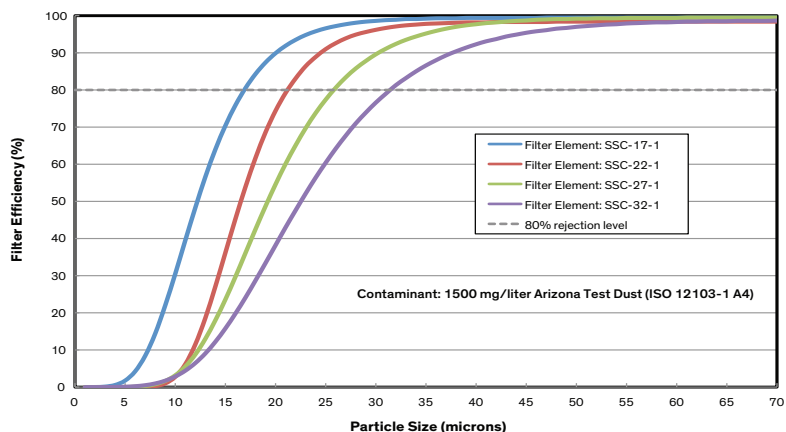

Figure 3: Filter Removal Efficiency<sup>2</sup>

(Shows removal efficiency versus particle size rejection at indicated conditions.)



<sup>2</sup> Subject to specific operating conditions

Table 1: Operating Limits

Item	Value
Max Inlet Pressure, psi (bar)	100 (6.9)
Temperature <sup>3</sup>	45°F–140°F (7°C–60°C)
pH <sup>4</sup>	5–9 continuous
Max Particle Size	1/16 in. (2000 micron)

Table 2: General Specifications

Item	TEQUATIC PLUS F-50	TEQUATIC PLUS F-75	TEQUATIC PLUS F-150
Typical Flow Rates by Filter Element <sup>5</sup>			
SSC-17-1, gpm (m <sup>3</sup> /hr)	5–15 (1.1–3.4)	20–60 (4.5–13.6)	80–240 (18.2–54.5)
SSC-22-1, gpm (m <sup>3</sup> /hr)	7.5–17.5 (1.7–4.0)	30–70 (6.8–15.9)	120–280 (27.3–63.6)
SSC-27-1, gpm (m <sup>3</sup> /hr)	10–20 (2.3–4.6)	40–80 (9.1–18.2)	160–320 (36.3–72.7)
SSC-32-1, gpm (m <sup>3</sup> /hr)	12.5–25 (2.9–5.7)	50–100 (11.4–22.7)	200–400 (45.4–90.8)
Shipping Weight (dry), lb (kg)	39 (18)	197 (89)	984 (446)
Housing Lid	16 (7)	83 (38)	370 (168)
Housing Base	23 (10)	114 (52)	614 (279)
Dimensions			
A: Diameter, inches (cm)	16 (40.6)	27.5 (69.9)	46 (116.5)
B: Height, inches (cm)	18 (45.7)	31.5 (80)	64.5 (163.8)
Fittings (see Figure 2)			
C/D/E: Filtrate/Feedwater/Recirculation (Victaulic <sup>6</sup> ), inches	2	3	6
F: Concentrate (Victaulic), inches	2	2	4

<sup>3</sup> Consult factory for higher max temperatures. Minimum temperature dependent on water composition.

<sup>4</sup> Consult factory for pH outside of specified range  
<sup>5</sup> Flow rates will vary depending on water quality

<sup>6</sup> Victaulic is a registered trademark of Victaulic Company

To reach an expert, call us **direct** at 1-800-648-9260 for North America or at 650-800-7818 internationally. Or call our Customer Information Group at 1-800-447-4369 for North America, +800-3 694-6367 for Europe, 400-889-0789 for China, or +0800-0474714 for Latin America.

**Also visit [www.cleanfiltration.com](http://www.cleanfiltration.com) or [www.dowwaterandprocess.com](http://www.dowwaterandprocess.com).**

Notice: No freedom from infringement of any patent owned by Dow or others is to be inferred. Because use conditions and applicable laws may differ from one location to another and may change with time, Customer is responsible for determining whether products and the information in this document are appropriate for Customer's use and for ensuring that Customer's workplace and disposal practices are in compliance with applicable laws and other government enactments. The product shown in this literature may not be available for sale and/or available in all geographies where Dow is represented. The claims made may not have been approved for use in all countries. Dow assumes no obligation or liability for the information in this document. References to "Dow" or the "Company" mean the Dow legal entity selling the products to Customer unless otherwise expressly noted. NO WARRANTIES ARE GIVEN EXCEPT FOR ANY SPECIFIC WARRANTY SET FORTH HEREIN; ALL IMPLIED WARRANTIES OF MERCHANTABILITY OR FITNESS FOR A PARTICULAR PURPOSE ARE EXPRESSLY EXCLUDED.